

PLAN VIEW

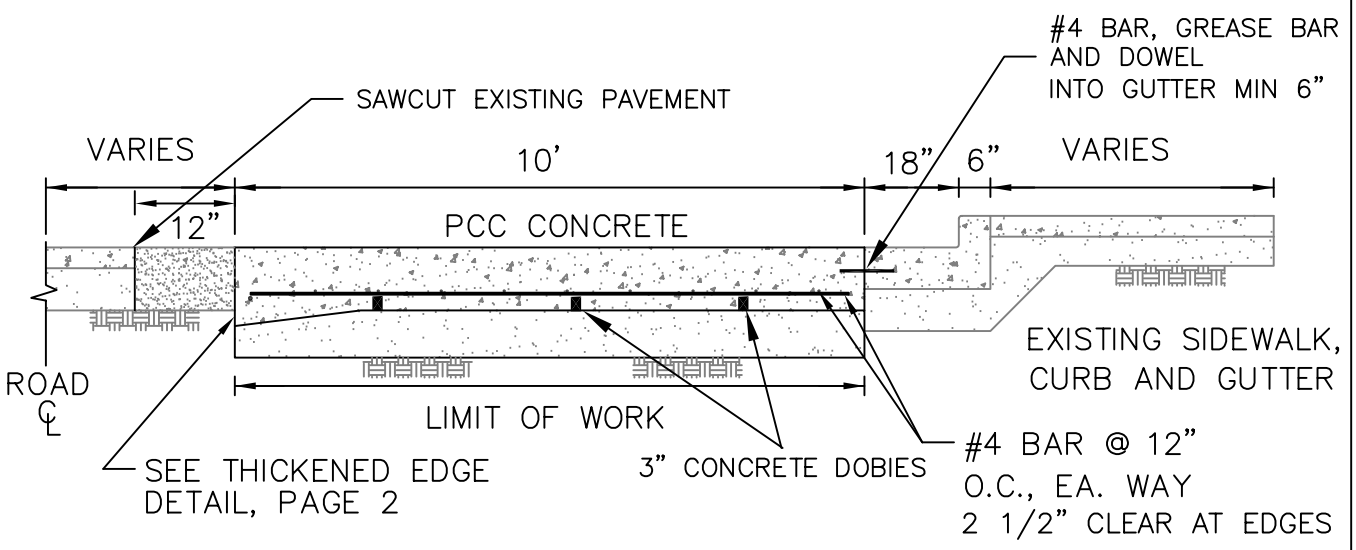

TYPICAL SECTION

No	By	Revision

**CITY OF SAN PABLO**

ONE ALVARADO SQUARE, SAN PABLO, CA 94806  
 (510) 215-3030 FAX 215-3031



Checked By: \_\_\_\_\_  
 Approved By: \_\_\_\_\_  
 PUBLIC WORKS DIVISION MANAGER    DATE

BUS PAD  
 PLAN AND SECTION

NO SCALE

STD DET SA-05  
 SHEET 1 OF 2

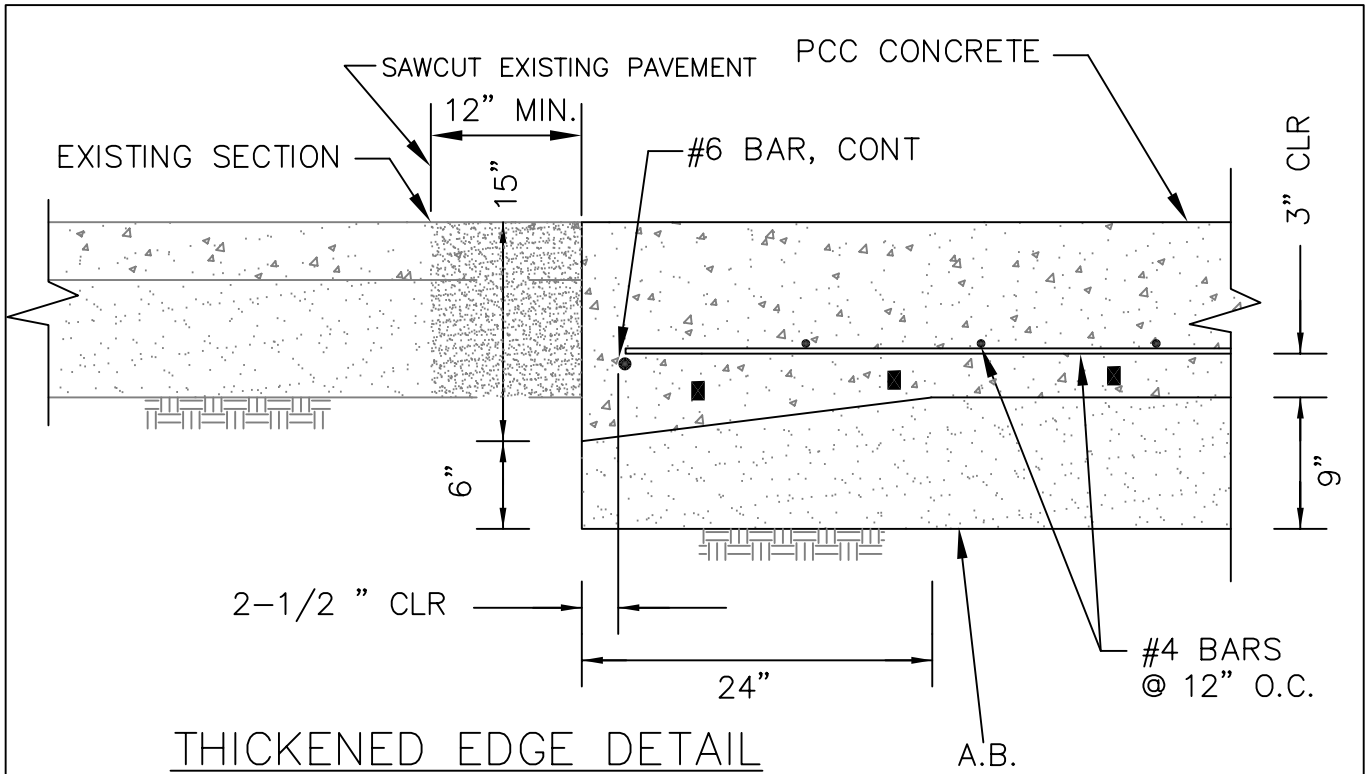

THICKENED EDGE DETAIL

A.B.  
SEE NOTE 4

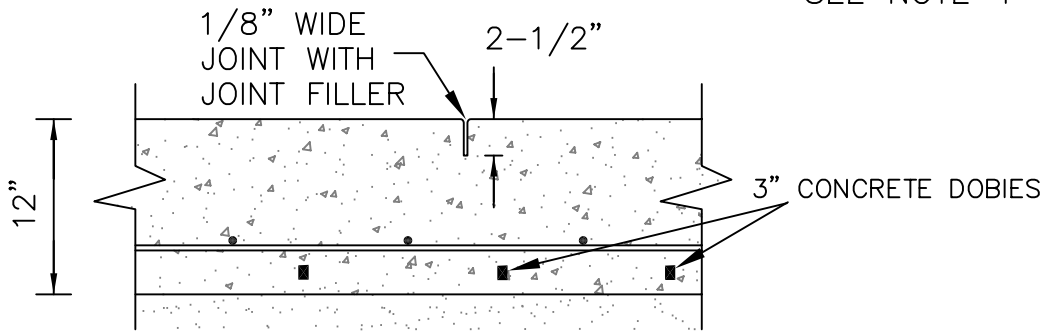

WEAKENED PLANE JOINT DETAIL

NOTES:

1. PLACE WEAKENED PLANE JOINTS AT 1/4 POINTS OR 20 FT. O.C. (MAX).
2. PORTLAND CEMENT CONCRETE SHALL BE 3,500 PSI, AS PER SECTION 90 OF THE CALTRANS STANDARD SPECIFICATIONS.
3. REINFORCEMENT SHALL BE GRADE 60, AS PER SECTION 52 OF THE CALTRANS STANDARD SPECIFICATIONS.
4. AGGREGATE BASE SHALL BE CLASS 2, AS PER SECTION 26 OF THE CALTRANS STANDARD SPECIFICATIONS. COMPACT TO 95% RELATIVE COMPACTION AS PER ASTM D-1557.
5. THICKEN ALL ENDS AND OUTSIDE EDGES AND REINFORCE WITH A #6 REBAR AS SHOWN ABOVE.

No	By	Revision

**CITY OF SAN PABLO**

ONE ALVARADO SQUARE, SAN PABLO, CA 94806  
(510) 215-3030 FAX 215-3031



Checked By: \_\_\_\_\_

Approved By: \_\_\_\_\_

\_\_\_\_\_  
PUBLIC WORKS DIVISION MANAGER      DATE

**BUS PAD  
DETAILS AND NOTES**

NO SCALE

STD DET SA-05

SHEET 2 OF 2